

---

# Guide to Decentralized Energy Technologies



September 2003



---

---

# Contents

<i>Introduction.....</i>	<i>i</i>
<i>Cogeneration Technologies.....</i>	<i>1</i>
<i>'Recycled' Energy Technologies.....</i>	<i>29</i>
<i>Renewable DE Technologies.....</i>	<i>31</i>
<i>References .....</i>	<i>40</i>

# Introduction

## **BRIEF HISTORY OF ELECTRICITY PRODUCTION**

Electricity, distributed to every stationary requirement for light and power, is the defining innovation of human history, replacing muscle power and candles with on-demand power. In the first 100 years post commercialization in 1880, optimal generation technologies were inherently remote, or central. Hydroelectric plants must be located where water falls, old style coal plants were not nice neighbours, and nuclear power reinforced the trend to central generation.

To speed electrification, governments everywhere passed laws granting central generation protection from competition, creating monopolies. Over the past 20 to 40 years, numerous factors have combined to make decentralized generation – at or near users – the optimal method of heat and power generation. However, as is often the case, yesterday’s laws remain in place, protecting yesterday’s optimal approaches, to the detriment of today’s citizens.

The World Alliance for Decentralized Energy (WADE) was formed by energy professionals from all over the world who believe the ruling central generation paradigm is no longer optimal, and that moving to decentralized generation will improve standards of living and reduce environmental damage. This Guide explains the decentralized generation vision of WADE.

## **DECENTRALIZED ENERGY**

WADE defines decentralized energy (DE) as the production of electricity at or near the point of use, irrespective of size, fuel or technology. DE can be on-grid or off-grid and can be powered by a wide variety of fossil fuels.

DE can be broken into two main divisions:

- High efficiency cogeneration of heat and power, with capacities ranging from 1 kW to over 400 MW and which include reciprocating engines, gas turbines, steam turbines, Stirling engines, fuel cells and microturbines. Cogeneration, also known as combined heat and power or CHP, is a proven and reliable concept that recycles heat that is a byproduct of all combustion-based electrical generation and has been used widely in industry and buildings throughout the world;
- On-site renewable energy systems and energy recycling technologies that capture otherwise wasted energy. These can include photovoltaic and biomass systems, on-site wind and water turbine generators, plus systems powered by gas pressure drop, exhaust heat from industrial processes, and low energy content combustibles from various processes.

## **AN INTRODUCTORY GUIDE TO DE**

There is a growing worldwide acceptance that decentralized electric generation will reduce capital investment needs compared to central generation with its supporting transmission and distribution systems. In addition, decentralized generation can lower the cost of electricity, reduce pollution, reduce production of greenhouse gas, and decrease vulnerability of the electric system to extreme weather and terrorist attacks. While DE is unlikely to replace central power entirely, many now believe that the share of DE in global power generation will increase dramatically in coming years, with important benefits to all segments of the population and significant environmental benefits.

One important means of accelerating the transition is to reach out to new audiences and introduce the concept of DE, including general information on the technologies themselves and the economics of their operation.

This Introductory Guide has therefore been produced by WADE to provide a standard source of information about DE technologies, both commercial and pre-commercial, which form the basis of decentralized energy development around the world today. Much of the material will be familiar to established DE practitioners and developers, but for those now arriving it is hoped that the Guide will serve as a valued source for some time to come.

## **ABOUT WADE**

WADE is a non-profit association working to accelerate the deployment of decentralized energy systems worldwide.

WADE was established in June 2002 and is now backed by national cogeneration and DE organizations, DE companies and providers, the governments of Norway, the USA and Canada, and the UN. In total, WADE's direct and indirect membership support includes over 200 corporations around the world.

WADE believes that the world's electricity systems are in need of significant modernization and development along more sustainable and cost-effective lines. To achieve this requires the implementation of 'WADE's Seven Guiding Principles for Effective Electricity Regulation':

1. There should be a fully independent and properly resourced regulator of the electricity system;
2. Electricity system pricing should be fully cost reflective with no cross subsidies from one part of the system to another;
3. Power generation and supply companies should have no ownership or management interest in the network;
4. All generators of electricity should have fair and non-discriminatory access to the grid;
5. Use of T&D networks should be priced according to the services they provide and not in such a way as to incentivise distribution companies to avoid DE interconnection;
6. Utilities should be required to engage in cost benefit analysis which can enable DE to be developed in areas where its local benefits outweigh the costs of constructing or upgrading new distribution facilities;
7. The electricity system should be subject to market based instruments, for example emissions trading, energy taxation and output-based standards, which fully reflect energy conversion efficiencies and internalise environmental costs of energy conversion.

Further information about WADE is available at [www.localpower.org](http://www.localpower.org), or contact:

Michael Brown  
Director  
WADE  
15 Great Stuart Street  
Edinburgh, EH3 7TP, UK  
+44 131 625 3333, fax 3334  
[michael.brown@localpower.org](mailto:michael.brown@localpower.org)

Thomas R. Casten  
Chairman & CEO  
Primary Energy LLC  
2000 York Road, Suite 129  
Oak Brook, IL 60523, USA  
+1 630 371 0505, fax 0673  
[tcasten@primaryenergy.com](mailto:tcasten@primaryenergy.com)

# 1

## Cogeneration Technologies

### THE COGENERATION (CHP) CONCEPT

Cogeneration is the process of producing both electricity and usable thermal energy (heat and/or cooling) at high efficiency and near the point of use. The range of technologies available allows the design of cogeneration facilities to meet specific onsite heat and electrical requirements. Figure 1 summarizes the concept.

FIGURE 1: Conventional Power and Cogeneration compared

#### Separate Production of Electricity and Heat

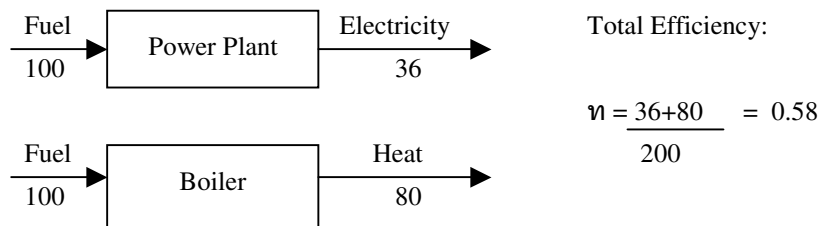

#### Cogeneration

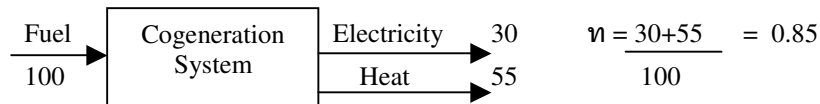

There is a strong existing technological platform from which cogeneration can develop. And there are some newer technologies that - although still in their developmental stage - have the potential to further improve the economic and environmental optimality of cogeneration in the future.

### **THREE PRINCIPLES**

There is a popular misconception that the electric system of generation and distribution must be economically optimal. A few basic principles of heat and power generation and distribution will help explain why DE improves on all measures of system performance.

#### **INEVITABLE BY-PRODUCT - HEAT**

Fuel is like whole milk. Milk from the animal contains varying amounts of cream, with the remainder skim milk. Farmers selectively breed cows for higher cream production and then utilize highly efficient cream separators in order to extract the maximum possible amount of high value cream. All farmers then sell the remaining skim milk.

The production of electricity has remarkable parallels. Power professionals select technologies that convert maximum possible fuel energy to high value electricity, but are inevitably left with significant quantities of by-product heat. Then central and decentralized generation diverge. For reasons more fully explained below, the central generation plant cannot economically move its by-product heat to thermal users. Instead, central power plants use power to drive cooling tower pumps and fans that reject the heat to atmosphere, or simply dump the heat into nearby rivers, lakes and oceans. By contrast, decentralized generating plants, located at or near thermal users, can recycle the by-product heat to offset burning of other fossil fuel.

National central generation based electric systems seldom achieve delivered efficiency above 33%. By contrast, cogeneration plants, by recycling normally wasted heat (skim milk in this analogy), can (and do) achieve overall efficiencies in excess of 85%.

## THE RULE OF SEVENS

Ton Van der Does, widely regarded as the father of cogeneration in the Netherlands and a WADE founder, created the “Rule of Sevens.” Ton observed that it requires roughly seven times more energy to move a megawatt-hour of electricity as to move a megawatt-hour of chemical energy – fuel. But it also takes seven times more energy to move a MWh of thermal energy than to move a MWh of electricity. It therefore takes 49 times more energy to move a MWh of thermal energy than to move the same MWh of fuel or chemical energy.

These relationships explain why remote central generating plants are unable to economically recycle by-product thermal energy. It simply costs too much energy and capital to transmit thermal energy long distances. And the amounts of by-product thermal energy are enormous. For example, the Indian Point nuclear generating station in the USA rejects an amount of by-product heat into the Hudson River that exceeds the thermal energy requirements of all of the buildings in Manhattan. Power from Indian Point power flows to Manhattan, 45 miles to the south, but it is prohibitively expensive to transmit the heat the same distance, so it is wasted.

## INDUSTRIAL WASTE HEAT AND WASTE FUEL

Many industrial processes, such as the production of steel, aluminium, metal castings, chemicals, petroleum, carbon black and glass, reject significant streams of waste heat and/or low-grade gas. These energy streams are both difficult and expensive to transmit over any distance but can be converted locally into heat and power. The energy potential of this resource has not yet been fully quantified, but is likely to be in the hundreds of gigawatts worldwide.

## STEAM TURBINES – RANKINE CYCLE POWER

FIGURE 2: Steam Powered District Heating Cogeneration Plant



(Courtesy of Applied Global Cogeneration)

One of the most common power generation technologies today is a Rankine Cycle plant based on steam and turbine driven generators. Virtually all of the world's coal, nuclear and other solid fuelled power plants boil water to produce high pressure steam which is then used to turn a steam turbine that powers a generator. In addition, many central generation plants utilize boilers burning natural gas or oil in the same cycle.

Steam turbines are applied in two quite distinct approaches – condensing and backpressure. The efficiency of fuel conversion to power is 20% to 38% from condensing turbines and, to energy, is 80% to 90% for backpressure turbines. There are no technologies yet invented that convert over 60% of the energy in fuel to power, and the average delivered efficiency for the entire power system hovers around 33%. The remaining 2/3's of the energy content of the fuel is typically wasted – vented to atmosphere by central power plants.

Central plants, with no economic possibility of transmitting by-product heat to remote thermal users, utilize condensing steam turbines. By contrast, decentralized generating plants, located at or near thermal users, typically utilize backpressure turbines. These plants first extract power, usually as electricity,

from the pressure drop between the boiler and distribution pressure, and then send the lower pressure steam to nearby process and heating users.

Backpressure steam turbines have traditionally been the most popular prime mover technology in decentralized electricity generation, ranging in size from 0.05 MW-500 MW for cogeneration applications. Electrical efficiencies are low (7-20%) but overall efficiencies of 80% and above can be achieved, after crediting the recycled thermal energy. Their convenience is largely due to the fact that the required steam can be produced from a range of fuels, including coal, oils, gas and biomass. The fuel is used to heat water in a boiler and does not come into direct contact with the steam or the turbine, meaning that only the calorific value of the fuel is important - the cleanliness or quality of the fuel is largely irrelevant as far as turbine operation is concerned.

The heat produced during combustion of the fuel is used to raise steam in a boiler to high pressures and temperatures. Once the steam has reached its designated temperature and pressure, it is passed through the turbine blades at high velocity. The impact of the steam on the blades creates the mechanical rotation that turns the generator. The power produced by the generator depends on the drop in steam pressure through the turbines. The remaining heat in the outlet steam can be processed to meet the onsite requirements.

#### BACK-PRESSURE TURBINES

Back-pressure turbines expand high-pressure steam through a turbine. The output steam is exhausted at a relatively low pressure suitable for onsite heat requirements (see figure 3). It is possible to release the steam at various points through the turbine allowing access to more than one grade of heat; the extraction of steam from the turbine will result in a decrease in power across the blades.

#### CONDENSING TURBINES

In a condensing turbine, steam is exhausted into a condenser, achieving maximum possible pressure drop across the blades. The condensing steam turbine thus generates more electricity from a given quantity of high-pressure steam than a backpressure turbine, but then wastes all of the thermal energy.

**FIGURE 3: Back Pressure and Condensing Steam Turbines**

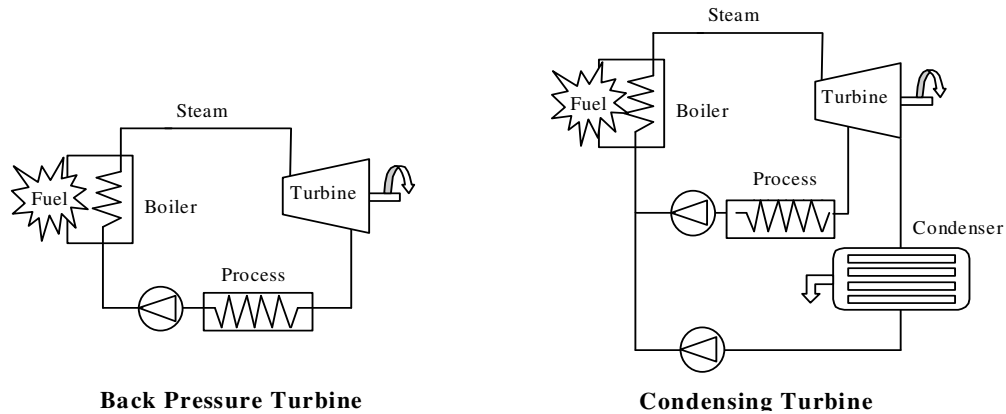

### APPLICATIONS OF HEAT

- Providing high-grade heat for industrial process plants. Condensing turbines are generally used for these applications due to the ability to control the electrical output by varying the mass flow rate of the steam.
- Providing heat for district heating systems - a suitable application for both backpressure and condensing turbines.
- Use of organic fluids such as iso-butane or propane in lieu of water enables turbines to extract more power at lower temperatures, and then either use or reject the remaining heat.

### PROS OF BACKPRESSURE STEAM TURBINES

- High overall cogeneration efficiencies of up to 80%;
- A wide range of possible fuels including waste fuel and biomass;
- An established technology;
- Production of high temperature/pressure steam.

### CONS

- Low electrical efficiencies;
- Need for expensive high-pressure boilers and other equipment;
- Slow start up times;
- Poor part load performance.

## ECONOMIC PERFORMANCE

Backpressure steam turbine cogeneration systems use a mature technology, with a long and successful history. The economic performance is well proven in situations where there is demand for both electricity and large quantities of steam. In addition, recycling energy nearly always involves steam turbines. As a general rule, the recycling of waste heat, low grade by-product fuel or gas pressure drop is achieved with Rankine cycle technology, usually steam turbines, turboexpanders or occasionally organic fluid turbines. The exception is a Stirling engine, which can also use heat to produce power. Where the fuel is natural gas or distillate oil, gas turbines, reciprocating engines and fuel cells often have advantages relative to Rankine cycle based steam turbines.

**TABLE 1:** Cost range for Steam Turbines<sup>i</sup>

Installed Capital Cost (\$/kW)	Operating and Maintenance (\$/kWh)	Levelized Cost (\$/kWh)	
		8000hrs/year	4000hrs/year
400 - 1,500	< 0.4	2.5 - 6.5	4.0 - 12.0

As table 1 shows, installed capital costs for steam turbines vary from \$400 - \$1,500 depending on size, required inlet and exit steam conditions, rotational speed and standardisation of construction.

Installed costs can be broken down into:

- 25% - boiler
- 25% - fuel handling, storage and preparation system
- 20% - stack gas cleanup and pollution controls
- 15% - steam turbine generator
- 15% - field construction and plant engineering

Because of the steam turbine's maturity, there is little scope for cost reduction or further efficiency gains. The only area where significant cost reductions could be made is in the fuel handling, storage and preparation systems.

Backpressure steam turbines have been deployed in commercial operations with as little as 40 kW of output, and some practitioners claim future "plug and play" turbines will operate with fractional kW outputs, wherever steam pressure is deflated. Historically, backpressure turbines below 1 MW have faced economically prohibitive electric interconnection requirements and been confined largely to powering other rotating equipment such as pumps, fans and air compressors.

The operational lifetime of steam turbines often exceeds 50 years. Operating and maintenance costs (O&M) are low - frequently less than \$0.1c/kWh. Maintenance is minimal, given that the boiler operators are separately responsible for water treatment and nearly pure steam. Steam turbines require periodic inspection of auxiliaries such as lubricating-oil pumps, coolers and oil strainers and checking safety devices.

## **GAS TURBINES**

Gas turbines, ranging in size from a few hundred kilowatts to hundreds of megawatts, are currently the favoured prime mover in larger-scale cogeneration wherever natural gas is available at costs less than 3 to 4 times the equivalent energy cost of solid fuels. Modern gas turbines achieve 28% to 42% simple cycle efficiency – shaft power divided by input fuel - and lend themselves to application as combined cycle plants. The gas turbine exhaust, typically around 540°C, is often used to produce high-pressure steam, which then powers a second generator. This increases the electric efficiency to 45%-60%. Recycling by-product heat to satisfy local thermal needs lowers the electric production, but improves overall economics.

The gas turbine has undergone remarkable technological progress over the past 35 years, strongly driven by military and commercial aircraft needs, but also benefiting from advances in materials science. Combustion temperatures have been increased as blade materials were developed that could withstand the higher temperatures and/or were cooled. This has increased the simple cycle efficiency from 22% (best available gas turbine in 1978) to 42% in 2003. And mass production has lowered costs per kW.

Environmental performance has also undergone dramatic improvement. The typical 1978 gas turbine exhaust contained 200 to 500 parts per million of oxides of nitrogen, sufficient to create visible yellow plumes. Current production gas turbines have NO<sub>x</sub> emissions from 2 to 25 PPM, before external controls. Aero-derivative gas turbines can also be silenced and have comparatively low space requirements.

For operation, intake air passes through a compressor before being heated by the combustion of the fuel. The expanding air is then used to drive a turbine before exiting through the exhaust and heat processes (see figure 4). Compressors require a large amount of energy, making the choice of compressor crucial to the overall efficiency of the turbine.

FIGURE 4: Gas Turbine

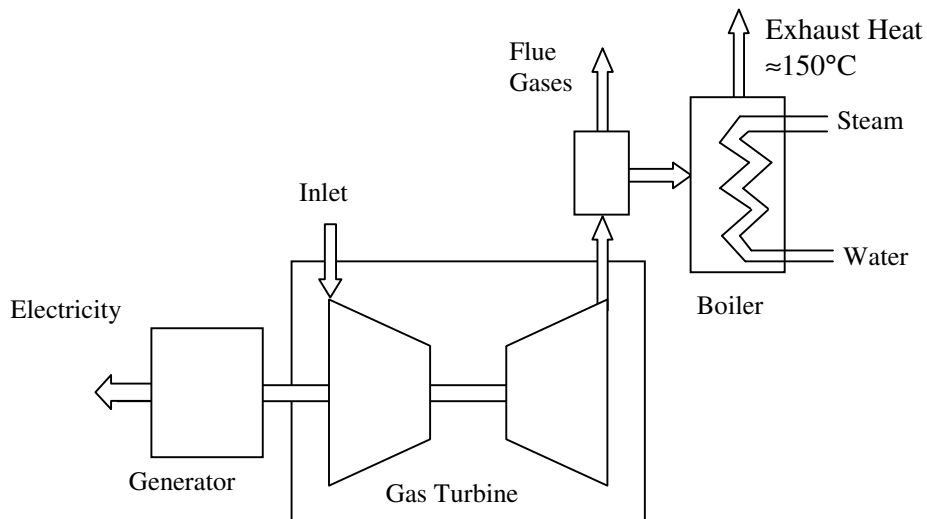

Due to the high oxygen content in the exhaust gas, the combustion of further fuel can be supported without the addition of extra air to raise the quality of heat. This process is known as supplementary firing - it can efficiently raise the exhaust gas temperature from around 500°C to 1000°C or more, raising the overall heat:power ratio of the cycle.<sup>ii</sup>

Since the combusted fuel passes through the turbine, clean gases must be used to avoid blade erosion. Natural gas is the main fuel source, but other fuels can be used. Distillate oils and gas oils are often used in combination with cheaper interruptible gas supplies. Waste fuels such as biogas and landfill gas can be used provided that their composition is consistent and their calorific values relatively constant. To improve electrical generating efficiency and reduce NO<sub>x</sub> it is possible to inject steam into the combustion chamber. NO<sub>x</sub> reduction methods have been successfully developed for gas turbines, but where very low emission levels are specified, it is possible to attach end of pipe solutions such as Selective Catalytic Reduction (SCR).

## APPLICATIONS OF HEAT

There are four main gas turbine cycles:

- Simple cycle gas turbines are generally used to provide peaking power or back up power without any provision of heat.

- Recuperated cycle gas turbines utilise the exhaust gas to preheat the compressed air before it enters the combustion chamber.
- Cogeneration cycle gas turbines provide both onsite heat and electricity achieving overall efficiencies of over 80%.
  - The high-grade heat can be used for producing process steam or chilling for industrial and commercial applications.
  - Alternatively exhaust gases can be used directly for drying processes in situations where direct contact with exhaust gases is permissible.
- For generating systems normally greater than 3 MW, it is possible to make use of the hot exhaust gases from a gas turbine to produce steam to power a steam turbine offering higher electrical efficiencies (35%-55%). Known as a combined cycle gas turbine (CCGT), these systems are best suited to public utility companies (without heat recovery) and industrial plants where there is an abundant supply of natural gas. The pass out steam from the steam turbine can be used, in cogeneration applications, to meet on-site heat requirements increasing overall efficiencies (73%-90%).

## PROS

- Easier to install than steam turbines and high pressure boilers with the added benefit of being less area intensive and having lower capital costs;
- Larger systems have high efficiencies with relatively low capital cost;
- High temperature steam production.

## CONS

- Gas turbines require premium fuels, especially natural gas, that has had historically high price volatility;
- The high temperatures involved limit the type of materials that can be used therefore raising production costs;
- Reduced efficiencies at part load;
- Turbine performance is significantly reduced at higher altitudes or during periods of high ambient temperatures;
- Small system costs are relatively high and efficiencies are lower than with some other generation systems.

**ECONOMIC PERFORMANCE**

Gas turbines are a mature and economically efficient technology with broad acceptance in the electricity market place.

**TABLE 2:** Cost range for Open Cycle Gas Turbines and CCGT/cogeneration<sup>iii</sup>

	Installed Capital Cost (\$/kW)	Operating and Maintenance (\$c/kWh)	Levelized Cost (\$c/kWh)	
			8000hrs/year	4000hrs/year
Open Cycle Gas Turbine	800 - 1,800	0.3 - 1.0	4.0 - 5.5	5.5 - 8.5
CCGT/ Cogeneration	800 – 1,200	0.3 – 1.0	4.0 – 4.5	5.5 – 6.5

The installed capital cost of a gas turbine cogeneration system varies between \$800-\$1,800/kWh. This is due to large variations in turbine size from a few kW to many hundred of MW. The O&M costs range from \$0.3c-\$1.0 c/kWh.

Inspections and blade washing must be carried out, around every 4,000 hours or so, to ensure the turbine is free of excessive vibration due to worn bearings, rotors and damaged blade tips. Entire hot section replacement is often required at roughly five year intervals, and usually involves a complete inspection and rebuild of components.<sup>iv</sup> Therefore, O&M costs vary significantly depending on the quality of regular servicing.

## RECIPROCATING ENGINES

Reciprocating engines are based on the same principles as petrol and diesel automotive engines. They enjoy high volume mass production and are often the lowest capital cost per kW of capacity. They operate at relatively high electrical efficiencies (up to 45%) and are well suited to standby, peaking or medium scale cogeneration systems. Reciprocating engines currently account for the majority of DE units for continuous use under 5 MWe and for back-up power.<sup>v</sup>

The main disadvantage of reciprocating engines in cogeneration applications is the difficulty of recycling the multiple and relatively low-grade heat streams. Up to a third of the fuel energy is available in the exhaust at temperatures from 370-540°C, but the other rejected heat is low temperature, often too low for most processes. (Jacket cooling water at 80 to 95°C, lube oil cooling at 70°C and intercooler heat rejection at 60°C, all difficult to use in CHP).

Like automotive engines, reciprocating engines can be split into two categories; compression ignition (diesel cycle) engines and spark ignition (otto cycle) engines.

## COMPRESSION IGNITION ENGINES

Compression engines - similar in design to automotive diesel engines - are usually four-stroke direct ignition machines, often equipped with turbochargers and intercoolers. They achieve electrical efficiencies in the range of 35-55% and size range of 75 kW-60 MW.

The distillate and heavy oil fuelled reciprocating engines often use the diesel cycle, which relies on the heat of compression to ignite the fuel. The piston's compression stroke raises the pressure and temperature of the combustion air above the self-ignition temperature of oil, and then very high pressure injectors spray a mist of atomized fuel into the hot air, causing immediate ignition, expansion and power stroke. Natural gas or evaporated gasoline is more difficult to ignite with a compression engine and depends on spark plugs to ignite the fuel and create the combustion that leads to the power stroke.

Dual fuel engines can operate in the pure oil injection mode, but can burn up to 97% natural gas. A small amount of diesel is injected into the compressed air

and natural gas mixture to achieve ignition. Furthermore, since the engine can be run solely on diesel, it is suitable for interruptible gas supplies.

Naturally aspirated reciprocating engines pull air into the pistons on the intake stroke, but then limit the amount of fuel and thus power produced to match available oxygen in the intake air. Superchargers, driven by external power, were used to increase the air packed into a cylinder on the intake stroke, thus increasing the amount of fuel injected and power produced from a given size cylinder. Modern engines replace the supercharger with a turbocharger / compressor package that recovers pressure drop from exhaust gas with an extremely high-speed expander turbine (up to 12,000 revolutions per second). This expander is directly connected to a similar compressor wheel that raises the pressure of the air in the intake manifold to over twice atmospheric pressure. To further increase air into the cylinder, the compressed air, which has been heated by the compression, is aftercooled. This removal of some of the heat of compression allows more molecules of oxygen to enter the pistons on the intake stroke, further increasing the fuel that can be burned on each cycle and thus increasing the power.

Thanks to turbocharging and aftercooling, modern reciprocating engines achieve nearly double the power output of similar displacement naturally aspirated engines, without comparable increase in cost for block, pistons, etc. This has significantly lowered the capital cost of reciprocating engine based cogeneration systems.

Modern engines have delayed ignition timing and increased compression ratios, which help reduce NO<sub>x</sub> without compromising power output and efficiency. The larger compression engines fuelled by diesel have to use SCR to control NO<sub>x</sub> emissions.

## SPARK IGNITION ENGINES

Spark ignition engines are a derivative of compression ignition engines, the difference being that a high intensity spark as well as compression is used to instigate the combustion. Spark ignition engines have a smaller size range when compared to compression ignition engines, ranging from 15 kW-10 MW. To obtain lower NO<sub>x</sub> emissions, modern spark engines use a pre-chamber to create a near stoichiometric mixture (an exact ratio with no excess of reactants) of the fuel with air. However, due to the possibility of knocking - caused by over

rapid combustion of fuel in the cylinder - the spark ignition engines are unable to match the same electrical efficiencies as compression engines – ranging from 25-43%. Spark ignition engines also give less heat to the exhaust gas and more heat to the cooling system. Natural gas is the most popular fuel, though biogas and other gases can be used.

Reciprocating engines operate with significantly less excess air than gas turbines. The gas turbine depends on the mass of air and fuel to turn blades and typically uses four times the air needed for complete combustion of the fuel. By contrast, reciprocating engines use one and one-half to two times the air needed to supply the oxygen needed for fuel combustion. As reciprocating engines are tuned to use less air, combustion temperatures increase with detrimental effects on NO<sub>x</sub> production. NO<sub>x</sub> production is related to the fourth power of the temperature of combustion, but does not begin to form below about 1300°C. Thus, although excess air reduces engine fuel efficiency, it is usually essential to control NO<sub>x</sub> emissions.<sup>vi</sup>

FIGURE 5: Reciprocating Engine Including Boiler Setup

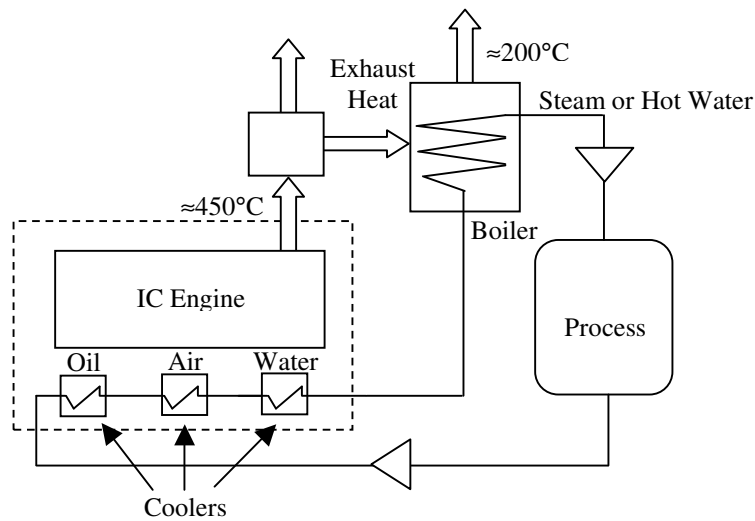

## APPLICATIONS OF HEAT

Low maximum temperatures in the cooling system limit useful heat recovery. However, in some cases where technical difficulties have been overcome, supplementary firing can be used to increase the quality of heat.

- Depending on size, reciprocating engines can be used to produce up to 15 bar of steam from the exhaust gases with independent production of hot water at 85-90°C from the cooling system;
- If the heat from the exhaust gases and cooling systems are combined it is possible to produce water at 100°C and steam at higher temperatures;
- The exhaust gases can also be directly recuperated and used for drying or CO<sub>2</sub> production. All residual energy from the engine can be used to produce hot air.
- Reciprocating engine cogeneration is typically applied in buildings and institutional settings, and less frequently for industrial use.

## PROS

- Lowest first cost of all CHP systems;
- High efficiencies at part load operation give users a flexible power source allowing for a range of different applications;
- Short start-up times to full loads (10-15 seconds), make reciprocating engines a favourable source for backup power systems and peak shaving applications;
- High reliability.

**CONS**

- Relatively high vibrations in reciprocating engines require support and special foundations with shielding needed to reduce acoustic noise;
- Large number of moving parts increases all-in maintenance costs to over \$10/MWh, compared to \$4.5/MWh for gas turbines, strongly offsetting the fuel efficiency advantages;
- Full utilization of the varied heat sources is difficult;
- Frequent maintenance intervals - every 600 to 1000 hours.

**ECONOMIC PERFORMANCE**

Through time reciprocating engines have achieved low initial capital costs, strong O&M support networks and high partial load efficiency. They achieve greatest economic benefits when used in small to medium size applications from 1 kW-5 MW.

**TABLE 3:** Cost range for Reciprocating Engines<sup>vii</sup>

Installed Capital Cost (\$/kW)	Operating and Maintenance (\$/kWh)	Levelized Cost (\$/kWh)	
		8000hrs/year	4000hrs/year
900 - 1,500	0.5 - 2.0	4.5 - 5.5	6.0 - 8.0

As table 3 shows, the installed cost for reciprocating engines is between \$900-1,500/kW. How these are broken down is shown in figure 6.

**FIGURE 6:** Total installed cost for a 500 kW Reciprocating Engine<sup>viii</sup>

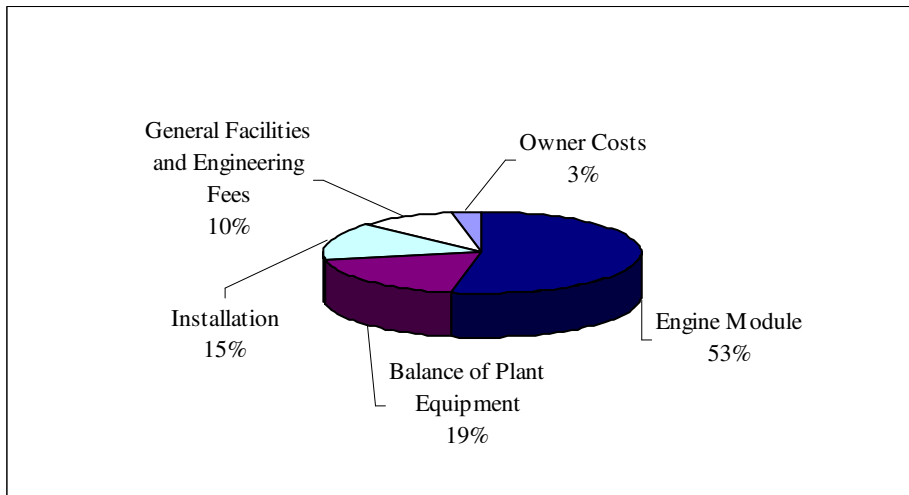

## STIRLING ENGINES

The Stirling engine is an external combustion engine allowing, in theory, for a range of fuel sources such as combustible gas or solar energy. The heat supplied to the engine causes the working fluid to expand, moving the piston. A displacer then transfers the fluid into the cold zone of the engine where it is recompressed by the working piston. The fluid is transferred back to the hot region of the engine and the cycle continues (see figure 7). The purpose of the regenerator is to capture heat from the working fluid as it moves from the hot to cold part of the engine with the heat being given back to the fluid on its return journey - this reduces the amount of fuel needed to reheat the working fluid. The noise created by a Stirling engine is considerably less than other technologies due to the low number of moving parts and the absence of internal combustion. Due to the retention of the working fluid, Stirling engines have high theoretical efficiencies. However, the limitations of materials, heat transfer efficiency and engine design currently constrain overall efficiencies.

The major challenge facing developers of Stirling engines is overcoming the lead in mass production and thus cost reduction enjoyed by reciprocating engines, which enjoy very high volume production for transportation applications. The advantage of Stirling technology is its ability to extract energy from any waste heat steam, regardless of corrosive properties of the exhaust or fuel. Current Stirling engine producers have focused on solar and waste heat applications, where their competition is the efficiency of PV power generation, or small Rankine cycle steam turbines.

FIGURE 7: Stirling Engine Schematic

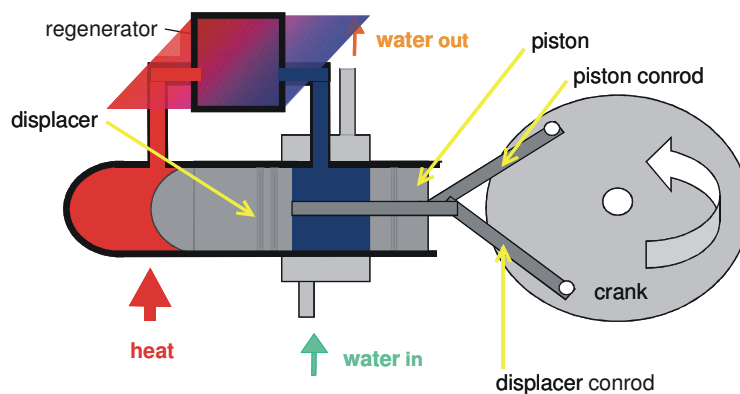

(Courtesy of A. Collinson - The Future of Embedded Generation)

### APPLICATIONS OF HEAT

- With a size range of 1kW (or less) to 25kW (and in the future up to 100 kW), Stirling engines are suitable for residential or portable applications. The small size and quiet operation mean that they would integrate well into a domestic environment;
- There is the possibility of using a solar dish to heat the Stirling engine eradicating the need for combustion of a fuel.

### PROS

- Low power-to-heat ratio makes Stirling engines suitable for use in domestic applications;
- Fewer moving parts than conventional engines, limiting wear on components and reducing vibration levels;
- Constant burning of fuel as opposed to pulsed combustion reduces noise;
- Low emissions of NO<sub>x</sub> and unburned fuel;
- Fuel versatility because the application of heat is external. This also allows for a wide range of fuels to be used and creates the possibility of altering the heat input to control the electrical output.

### CONS

- High cost and reliability issues;
- Low power efficiency.

### ECONOMIC PERFORMANCE

As with other emerging technologies analyzed in this report, the ultimate commercial success of Stirling engines depends upon economies of scale being achieved through mass production.

TABLE 4: Cost range for Stirling Engines<sup>ix</sup>

Installed Capital Cost (\$/kW)	Operating and Maintenance (\$c/kWh)	Levelized Cost (\$c/kWh)		
		8000hrs/year	4000hrs/year	2000hrs/year
2,000 - 5,000	0.1 - 3.5	5.0 - 9.5	8.0 - 19.0	14.5 - 34.0

Capital costs of Stirling engines, at present, are between \$2,000-\$5,000/kW.

They are not currently competitive with other DE technologies. O&M costs remain unclear. However, because of the relative simplicity of the technology they are thought to be relatively low, between \$0.1c-\$3.5c/kWh. Research into reducing the costs of Stirling engines has shown that there are a number of material-related issues specific to the design architecture that must be addressed. Once this has been achieved, costs of Stirling engines, and other emerging DE technologies, will fall.

## MICROTURBINES

Microturbines are small high-speed generator plants with an electric output range from 25-500 kW. Microturbines evolved from automotive and truck turbochargers, auxiliary power units for airplanes and small jet engines. They consist of a single shaft connecting a turbine, compressor and generator. Air is drawn in through a compressor into a recuperation unit that has been heated by the exhaust gases. The air flows into a combustion chamber where it is mixed with the fuel and burned. The hot gas is expanded through the turbine creating mechanical energy. The exhaust gases pass out through the recuperation unit to capture some of the remaining heat.

**FIGURE 8:** Capstone Microturbine - Generator System



Microturbines are predominately fuelled by natural gas, but diesel, petrol or biogas can be used. Some turbines use air bearings eliminating the need for lubricating oil. The use of air as a cooling source removes the need for more complex cooling systems.

Several microturbines in production today gain the efficiency of very high speed power turbines, directly connected to a high-speed generator that produces extremely high frequency alternating current – up top 100,000 Hertz. This enables very high power density relative to weight, but produces current that is of no use to existing power systems without solid-state transformation.

To solve this problem, the high frequency AC is sent to a rectifier that converts the energy into direct current. Solid state devices then convert the direct current into alternating current with a shaped profile of local power, either 50 or 60 cycle alternating current. This approach increases the capital cost, due to the

solid state inverter cost, but produces very clean power, suitable for sensitive applications, and these systems are inherently simpler to parallel with utility grids.

Microturbine manufacturers aim for significant mass production of standardized units relative to all other decentralized generation technologies, which could lower the cost and enhance competitiveness of these devices in cogeneration applications.

### APPLICATIONS OF HEAT

- The heat produced by a microturbine can be used to produce low-pressure steam or hot water for on-site requirements;
- Microturbines are well suited to provide heat and electricity to small commercial applications such as restaurants, hotels and offices.

### PROS

- Microturbines can be used for back up power for public utilities and commercial applications, as well as providing options for peak shaving;
- ‘Black start’ capability, which enables the system to operate with or without a grid interconnection;
- High overall efficiencies of up to 85% with heat recovery.

### CONS

- Relatively low electrical efficiencies of 20-30%;
- Efficiency is sensitive to changes in ambient conditions.

### ECONOMIC PERFORMANCE

Microturbines are not yet mass-produced and costs remain relatively high.

TABLE 5: Cost range for Microturbines<sup>x</sup>

Installed Capital Cost (\$/kW)	Operating and Maintenance (\$/kWh)	Levelized Cost (\$/kWh)	
		8000hrs/year	4000hrs/year
1300 - 2500	0.5 - 1.6	5.0 - 7.0	7.0 - 11.0

Some cost reduction will be further achieved as production costs fall over the longer term. One factor that may also drive cost reduction is the development of an integrated cogeneration package.

## FUEL CELLS

Fuel cells use the chemical energy created upon the oxidation of hydrogen to produce heat and electricity with a by-product of water (see figure 9). When hydrogen enters a fuel cell, a catalyst on the anode divides the hydrogen into  $H^+$  (hydrogen ion) and  $e^-$  (electron). The negatively charged electrons flow through an external load to the cathode, whilst the hydrogen ions pass through the electrolyte to the cathode, where they combine with oxygen and the electron to produce water and release energy (heat) - see equations 1 & 2 below. The voltage produced by a single fuel cell is small. However, fuel cells can be organised into stacks to provide the required power.

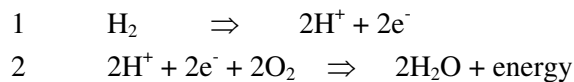
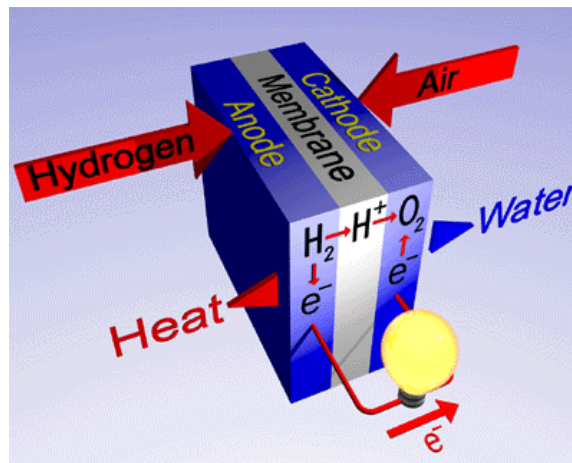

FIGURE 9: Fuel Cell Schematic



(Courtesy of FuelCell Energy)

A wide variety of technical approaches are used in fuel cells. Three approaches utilize low temperatures and have the advantage of rapid start, but the disadvantage of low efficiency. The phosphoric acid fuel cell has been in commercial use for over 35 years and have well proven reliability, but high first costs and low efficiency. The three low-temperature fuel cell technologies all

require hydrogen for fuel, necessitating a fuel reformer that converts commercial fossil fuel to hydrogen and CO<sub>2</sub>.

Two approaches – molten carbonate and solid oxide – both operate at temperatures of roughly 540°C and can require up to 8 hours from cold start to full power, making them undesirable for transportation motive power. However, they have several advantages that are especially apparent for stationary power generation. These advantages include:

- They reform fuel internally, avoiding a separate reformer and enabling them to use most commercial liquid and gaseous fuels.
- They achieve up to 50% fuel to electric efficiency today with theoretical possibilities of another 10 percentage points.
- The by-product heat is 260 to 370°C, suitable for most thermal uses.

TABLE 6: Fuel Cell Technology Summary<sup>xi</sup>

	Phosphoric Acid Fuel Cells (PAFC)	Polymer Electrolyte Fuel Cells (PEMFC)	Solid Oxide Fuel Cells (SOFC)	Molten Carbonate Fuel Cells (MCFC)	Alkaline Fuel Cells (AFC)
<b>Electrical Efficiency*</b>	36 - 42%	30 - 40%	45 - 60%	45 - 50%	70%
<b>Module Size Range</b>	100 - 200 kW	3 - 250 kW	1 - 10 MW	250 kW - 5 MW	10 - 200 kW
<b>Applications of Heat</b>	An operating temperature of 200°C allows recovered heat to be used for space or water heating, often suiting district heating systems	Can be used in cogeneration mode to produce hot water at 80°C. Ideal for space or water heating.	An operating temperature of 1000°C allows recovered heat to be used for industrial processes.	An operating temperature of 650°C allows recovered heat to be used for commercial buildings such as hospitals and hotels and for combined cycle applications.	With an operating temperature of 80°C AFCs would be ideal for use in stationary applications and in desalination plants.
<b>Pros</b>	The only fuel cells to be in commercial production. PAFC are seen to be the first generation of fuel cell technology	With low operating temperature, PEM fuel cells are easier to start up and are able to adjust to variable power demands	The solid electrolyte allows for a greater flexibility in design of the fuel cell. The high temperatures remove the need for a catalyst.	The quality of the heat enables higher electrical efficiencies.	High electrical efficiencies. Comparatively low cost manufacture.
<b>Cons</b>	Costs remain uncompetitive with other (non-fuel cell) technologies	The low operating temperature requires the use of an expensive platinum catalyst, which is degraded by carbon monoxide reducing the overall performance of the fuel cell.  The low operating temperature limits the cogeneration potential.	The high operating temperature creates some difficulties; expensive alloys are required at operating temperatures above 850°C but below 850°C ionic conduction becomes a problem and performance drop.  High temperatures can mean that it takes a long time for the electrolyte to heat up.	Molten lithium/potassium carbonate is chemically aggressive and puts strain on the stability and wear of cell components;  Long start up times to reach the operating temperatures.	Restricted to using pure hydrogen and oxygen as a fuel source

\* Electrical efficiencies are based on values for hydrogen fuel and do not include electricity required for hydrogen reforming.

### OVERALL PROS

- Fuel cells in general can provide heat for a wide range of applications;
- Show high electrical efficiencies under varying load;
- No moving parts, except fans;
- Low emissions;
- Quiet operation.

### OVERALL CONS

- With the exception of PAFC, no fuel cells are yet fully commercially viable;
- Largely unproven technology;
- There is no existing infrastructure for large-scale supply of hydrogen. (This only impacts low temperature fuel cells, as solid oxide and molten carbonate cells reform commercial fuels into hydrogen)

### ECONOMIC PERFORMANCE

The current installed capital cost of a fuel cell is approximately \$3,500-5,000/kW and costs are continuing to fall. O&M costs range between \$0.5c-\$5c/kWh and the levelized costs of electricity generation, at present, are above \$9c/kWh.

TABLE 7: Cost range for Fuel Cells<sup>xii</sup>

Installed Capital Cost (\$/kW)	Operating and Maintenance (\$/kWh)	Levelized Cost (\$/kWh)	
		8000hrs/year	4000hrs/year
3,500 - 5,000	0.5 - 5.0	9.0 - 11.5	14.5 - 19.5

The dominant supplier of stationary fuel cells today in terms of total MW of capacity is FuelCell Energy, which offers commercial models with 250 to 3,000 kW output. The company currently prices installed plants at around \$2,500 per kW, but continues to report losses, indicating continued subsidy of initial units. There have been significant and continuing reductions in the cost of balance of plant, and in production costs of the fuel cells, and management assures the public that they are on a path to produce fuel cell power plants with competitive costs.

O&M costs for fuel cells remains somewhat speculative, due to lack of history with the possible degradation of individual fuel cells and the life of the cells between replacements. The longest running molten carbonate fuel cells have less than three years of continuing operation, and it is not yet clear when stacks will need replacement.

# 2

## 'Recycled' Energy Technologies

Most energy-intensive industrial processes are similar when viewed from a 20,000-foot level. They begin with large volumes of raw material at ambient temperatures, add large quantities of fossil energy and/or electricity to raise the temperature and transform the raw materials, then exhaust three streams, including gases still containing combustible materials, exhaust heat, and ambient temperature finished goods. Much of the exhaust energy can be recycled to produce useful heat and/or power.

One example is an integrated steel mill that burns coke, pulverized coal and natural gas to melt iron ore, then cool the resulting iron into slabs. The blast furnaces produce large quantities of low-grade gas. Another example is a refinery that starts with 100 barrels of ambient temperature crude oil, burns roughly 8 barrels to raise the temperature of the feed stock to produce gasoline, jet fuel, distillate oil and residual oil, then cools all of the products to ambient temperature for shipping.

While these and other industries have often burned the waste gas to produce some of their needed steam, they have tended to concentrate on their core businesses and avoid investing in the opportunities for energy recovery.

The technologies used vary in the process of recovering the heat, but nearly all involve a Rankine cycle – pumping some fluid up to relatively high pressures, then using the heat to vaporize that fluid, and then producing shaft power with the pressure drop via an impulse turbine or turboexpander. Higher temperature applications typically use steam boilers while lower temperature processes find organic fluids such as iso-butane and propane more economic.

The recycled energy projects built to date range in capital cost from \$1000 to \$2500 per kW of capacity. Their operating costs vary by type of energy recycled, but generally track the relatively low maintenance costs of steam turbine technology.

Casten and Collins<sup>xiii</sup> have estimated potential for generating 42,000 MW in the US from recycled energy that is tracked in various data bases, and gone on to suggest up to 90,000 MW of total potential. Given the US consumes roughly 25% of total world energy, a rough approximation would suggest potential for 360,000 MW of recycled energy worldwide. This compares to 100,000 of installed total MW of generating capacity in India, or 800,000 installed MW in the US.

# 3

## Renewable DE Technologies

### SMALL SCALE HYDROPOWER

Hydropower releases the potential energy stored in water resting at altitude. Accounting for 17.5% of world electricity,<sup>xiv</sup> the majority of hydropower generation comes from large-scale projects. This section will consider the technologies involved in micro hydropower generation (up to 100 kW), mini hydropower generation (up to 1 MW) and small-scale generation (up to 10 MW) due to their suitability for decentralized generation.

### TECHNOLOGY

The technology applied to hydro systems depends on the scale of the project and the surrounding topography. Micro-hydro systems are usually ‘run of the river’ schemes where the flow of the river is not stopped. This avoids environmental issues such as the flooding of river valleys, the disruption of seasonal river levels or fish mortality. Larger projects frequently require total impediment of the flow, provided in the form of a dam or weir. It is often possible to integrate new DG systems into old civil structures left abandoned since the advent of centralised power.

In both systems a portion of the flow will be redirected - via a tunnel and/or a pressure pipe - to the turbine intake - in ‘run of river’ systems the natural variability in the flow is maintained. Once the water has passed through the turbine the flow is directed back to the river.

The pressure or head available to a hydropower system refers to the drop in height of the water available to the system - low head (6m-12m), medium head (30m-100m) and high head (100m+).

**FIGURE 10:** High Head Hydro System

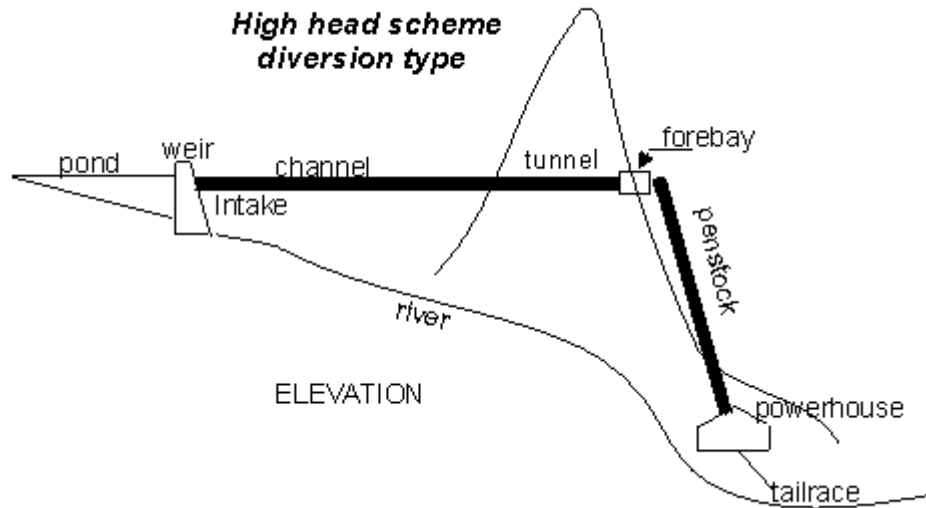

Essentially there are two different types of turbines used in hydropower: reaction turbines and impulse turbines. In reaction turbines, the pressure of the water supplies a force across the blades, which decreases as the water progresses through the turbine. In impulse turbines the water is converted into a high-speed jet that strikes buckets attached to the perimeter of the turbine.

Francis turbines, Kaplan turbines and Pelton wheels are the main turbines used in small-scale hydroelectric generation. Francis turbines are widely used in small-scale hydropower predominantly for medium and low head applications. They are radial flow reaction turbines with axial outlets for high-speed applications. Kaplan turbines are axial turbines typically used for low and ultra low head applications. Pelton wheels are impulse turbines that are ideally suited to medium and high head applications.

## APPLICATIONS

Micro-hydro systems can provide electricity to local residential communities or to small industrial applications. They are ideally suited to remote applications, in industrialized and developing countries.

## PROS

- Modern ‘run of the river’ technologies allow for the integration of turbines into the surrounding landscape minimising the level of environmental impact;
- The long life of hydro systems, together with the free ‘fuel’, can enable low cost electricity generation;
- Many sites, disused since the advent of centralized power, are being refurbished to again allow generation. This is a popular choice since the environmental impact of flooding a new site to allow for generation is frequently a barrier to development;
- The simple technologies involved in small-scale hydro make it an ideal power source for remote sites.

## CONS

- The suitability of a site depends on the security of the water supply and the volume or available head of the flow;
- ‘Run of the river’ schemes offer no water storage for dry spells;
- The output of the turbine is primarily governed by the flow in the river or the water catchment area;
- Excess electricity is wasted without storage or suitable off peak use.

## ECONOMIC PERFORMANCE

Small hydropower has high up front capital costs that are usually reclaimed over 10-20 years, corresponding to high electricity costs over this period. However, small hydropower systems often last for over 50 years without major investment, providing an overall lower cost for electricity production.<sup>xv</sup>

**TABLE 8:** Cost range for Small Hydro Power<sup>xvi</sup>

Installed Capital Cost (\$/kW)	Operating and Maintenance (\$/kWh)	Levelized Cost (\$/kWh)	
		8000hrs/year	4000hrs/year
1,450 - 5,600	≈ 0.7	3.5 - 8	N/A

Installed capital costs for small hydropower are between \$1,450-5,600/kW. O&M costs are often very low as little maintenance is required. Levelized costs are between \$3.5c-\$8c/kWh. In developing countries the cost of installing micro hydro systems is often kept down by applying lower cost but innovative practices.

## PHOTOVOLTAICS

Photovoltaic (PV) cells directly convert the light from the sun into electricity and represent an ideal form of decentralized power generation.

FIGURE 11: 750 Wp Solar PV Unit



Usually fabricated from silicon with traces of other elements, PV cells are solid-state semiconductors. PV cells work by absorbing particles of light (photons), which liberate electrons (negative) from the semiconductor layer leaving behind a positive 'hole'. An artificial 'positive/negative' (P/N) layer prevents the electron from returning to its 'hole' and allows for the generation of electricity (see figure 12). Generally arranged into modules, PV cells can be designed to match a wide range of electrical needs. Efficiencies for commercial PV cells range from 7-17%.

FIGURE 12: P/N Photovoltaic Layer

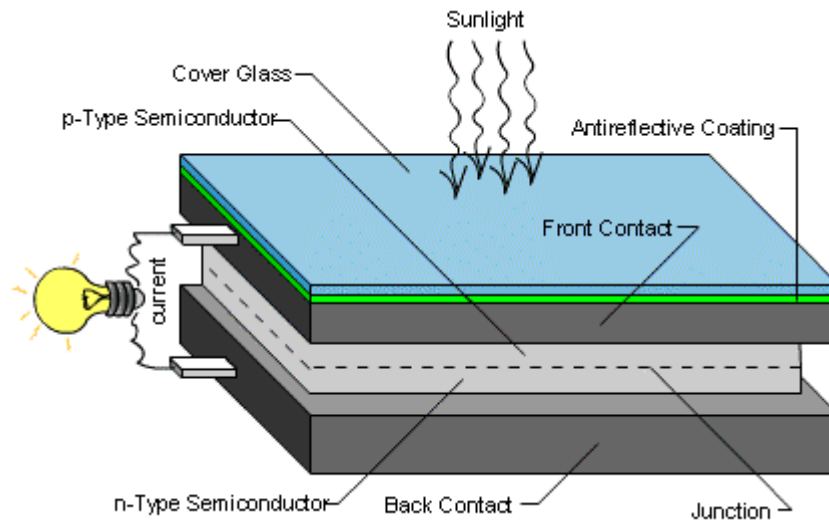

### CRYSTALLINE SILICON

Crystalline silicon (c-Si) is the leading commercial material in PV manufacture. Multicrystalline silicon cells are becoming more popular than mono-crystalline silicon because they are less expensive to produce despite being slightly less efficient. Cell efficiencies of 24.7% have been recorded for c-Si cells.<sup>xvii</sup>

### THIN FILM

Thin film cells consist of layers of semiconductor materials that have been sprayed onto the surface of glass, flexible plastic or stainless steel. Although performance levels for thin film cells are lower than those for c-Si cells, they have a lower material cost and offer the potential for low cost automation.<sup>xviii</sup> They also offer massive flexibility in the application of solar cells allowing for the potential integration into a wide range of products.

### MULTI JUNCTION

Multi junction devices maximise the amount of energy absorbed in the solar module by stacking different types of solar cells on top of each other. The top layer of the module absorbs the highest energy of light, with the rest of the energy being absorbed by the lower layers.

## FUTURE DEVELOPMENT

The development of dye-sensitized solar cells presents a potentially inexpensive and more flexible alternative to current semiconductor technology. The dye sensitized solar cells use a dye-impregnated layer of titanium dioxide to generate a voltage eliminating the use of semiconductors. Polymer and photoelectrochemical cells that use sunlight to produce hydrogen from water, once fully developed, are likely to play a key role in decentralized energy.

## APPLICATIONS OF SOLAR CELLS

Certain solar cells can efficiently convert concentrated solar energy enabling the reduction in surface area of PV modules for a given output. Fresnel lenses, mirrors and mirrored dishes can be used to focus and concentrate the light on the PV cells. PV cells have a low visual impact and are able to be integrated into a wide range of structures and buildings sometimes replacing construction materials.

Stand-alone PV systems provide power that is independent from the utility grid often proving cost effective when there is no nearby grid connection. The technology is ideal for rural areas and developing countries often being used for powering farm lighting, farm fencing and solar water pumps. Most systems that use power during nighttime hours require a battery for storage. However, it is possible to combine the PV cells in hybrid arrangements with wind power, or a diesel engine.

Grid-connected PV systems combine the independence of on-site generation with the reliability of the grid. Surplus electricity is supplied to the grid and when there is an energy deficiency the electricity is taken back from the grid, removing the need for battery storage.

## PROS

- There are no mechanical parts in PV cells eliminating any associated ‘wear and tear’;
- Low environmental impact;
- Large size range allowing for flexibility of application;
- No noise.

## CONS

- The high cost of PV cells is the main barrier preventing wide spread application, though costs have fallen and will probably continue to do so;
- Restricted to operation during certain conditions. No electricity is generated at night and cloudy conditions reduce efficiencies to 5-20% of full sun output;
- In some systems, toxic substances such as Cadmium are used and could be released from the cell if it is exposed to fire. Careful manufacture and recycling of toxic PV cells will minimise the risk.

## ECONOMIC PERFORMANCE

The cost of PV electricity generation has fallen 15 to 20 fold in less than 30 years and panels are now available between \$4,500-6,000/kW. O&M costs have the potential to be low as very little maintenance is required, but at present typical maintenance costs are 1% of capital investment/year.<sup>xix</sup> Because of the high capital costs, the cost of electricity generation is also high (\$34c-\$46c/kWh). This means that PV is only attractive in certain circumstances; for example, where there is no fuel supply, no grid connection and plentiful sunlight hours, PV systems may be the preferred source of electricity both in terms of cost and technical viewpoint.

**TABLE 9:** Costs for PV<sup>xx</sup>

Installed Capital Cost (\$/kW)	Operating and Maintenance	Levelized Cost (\$c/kWh)
		1850hrs/year
4,500 - 6,000	1% of capital cost/annum	34.5 - 46.0

Where there is a competitive market place, costs remain too high for PV to be economically efficient. Capital costs for most PV applications may have to drop below \$1,000/kW to be truly competitive.

As figure 13 shows, capital costs are projected to continue to decrease in the coming years, provided demand expands in order to enable unit production costs to fall.

FIGURE 13: PV System Prices<sup>xxi</sup>

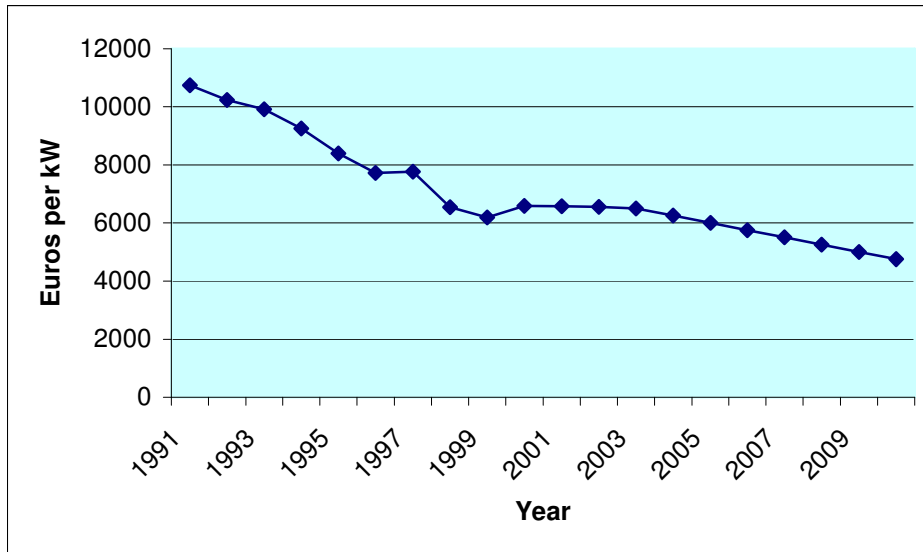

TABLE 10: Summary of Technologies<sup>xxii</sup>

Prime Mover	Condensing Steam Turbine	Back Pressure Steam Turbine	Open Cycle Gas Turbine	Combined Cycle Gas Turbine	Compression Ignition Engine	Spark Ignition Engine	Stirling Engine	Microturbine	Fuel Cell	Small Scale Hydro	PV
Fuel	Any Fuel	Any Fuel	Natural Gas Biogas Propane Distillate Oils	Natural Gas Biogas Propane Distillate Oils	Natural Gas Biogas Propane Distillate Oils	Natural Gas Biogas Propane Liquid Fuels	Any Fuel	Natural Gas Biogas Propane Distillate Oils	Hydrogen Natural Gas Propane	-	-
Size Range MW	1 - 100	0.5 - 500	0.25 - 500	3 - 300	0.08 - 20	0.08 - 20	0.001 - 0.025	0.025 - 0.5	0.01 - 10	<10MW	<1kW - 100kW
Electrical Efficiency (%)	10 - 20	7 - 20	25 - 42	35 - 55	35 - 45	25 - 43	12 - 20	20 - 30	30 - 70	90	7 - 17
Overall efficiency with cogeneration (%)	Up to 80	Up to 80	65 - 87	73 - 90	65 - 90	70 - 92	Up to 90	Up to 85	Up to 85	NA	NA
Installed Cost (\$/kW)	1,000 - 3,350	1,000 -3,500	800 - 1,800	800 - 1,200	900 - 1,500	900 - 1,500	2,000 -5,000	1,300 - 2,500	3,500 -5,000	1,450 - 5,600	4,500 - 6,000
O&M Costs (\$/kWh)	<0.4	<0.4	0.3 - 1	0.3 - 1	0.5 - 2	0.5 - 2	0 - 3.5	1	0.5 - 5	≈ 0.7	1% of capital per annum
Levelized Costs (in Cogeneration mode) 8000hrs/yr	2.5 - 6.5	2.5 - 6.5	4.0 - 5.5	4.0 - 4.5	4.5 - 5.5	4.5 - 5.5	5.0 - 9.5	5.0 - 7.0	9.0 - 11.5	3.0 - 10.0	34.5 - 46.0 (1850hrs/yr)

# References

<sup>i</sup> Based on typical cogeneration values. Levelized costs based on a coal price of \$0.5c/kWh, maintenance costs of \$0.4c/kWh, a discount rate of 8% with a ten year payback period, an electrical efficiency of 15% and an overall efficiency of 75%.

<sup>ii</sup> The European Association for the Promotion of Cogeneration, A Guide to Cogeneration, June 2001 available at [http://www.cogen.org/publications/reports\\_and\\_studies.htm](http://www.cogen.org/publications/reports_and_studies.htm)

<sup>iii</sup> Based on typical cogeneration values. Levelized costs based on a gas price of \$1.88c/kWh, maintenance costs of \$0.55c/kWh, a discount rate of 8% with a ten year payback period, an electrical efficiency of 35% and an overall efficiency of 80%.

<sup>iv</sup> Energy Nexus Group, Technology Characterization Gas Turbines, February 2002

<sup>v</sup> Financial Times Energy – Decentralised Energy

<sup>vi</sup> See note (ii)

<sup>vii</sup> Based on typical cogeneration values. Levelized costs based on a gas price of 1.88\$/kWh, maintenance costs of \$1.25c/kWh, a discount rate of 8% with a ten year payback period, an electrical efficiency of 45% and an overall efficiency of 85%.

<sup>viii</sup> See note (v)

<sup>ix</sup> Based on typical values. Levelized costs based on a gas price of \$1.88c/kWh, maintenance costs of \$1c/kWh, a discount rate of 8% with a ten year payback period, an electrical efficiency of 20% and an overall efficiency of 90%.

<sup>x</sup> Based on typical values. Levelized costs based on a gas price of \$1.88c/kWh, maintenance costs of \$1c/kWh (projected value), a discount rate of 8% with a ten year payback period, an electrical efficiency of 25% and an overall efficiency of 80%.

<sup>xi</sup> Global Equity Research, An Introduction to Fuel Cells, November 2000

Energy Research Centre of the Netherlands, Fuel Cell Technology, available on-line at <http://www.ecn.nl/bct/products/pemfc/principle.en.html>

California Energy Commission, Distributed Energy Resource Guide, available at <http://www.energy.ca.gov/distgen/index.html>

<sup>xii</sup> Levelized costs based on a gas price of \$1.88c/kWh, maintenance costs of \$2c/kWh, a discount rate of 8% with a ten year payback period, an electrical efficiency of 50% and an overall efficiency of 80%.

<sup>xiii</sup> Tom Casten and Martin Collins, Primary Energy Inc., <http://www.primaryenergy.com/>

<sup>xiv</sup> IEA Statistics, Electricity Information 2002

<sup>xv</sup> Peter Frankel, Flowing too slowly - Performance and potential of small hydro-power, Renewable Energy World, March 1999

<sup>xvi</sup> Based on typical values. Levelized costs based on a maintenance costs of \$0.7c/kWh and a discount rate of 8% with a ten year payback period.

<sup>xvii</sup> See note (v)

<sup>xviii</sup> Solar Access, Solar Energy Basics, available at <http://www.solaraccess.com/education/solar.jsp?id=pv>

<sup>xix</sup> See note (v)

---

<sup>xx</sup> Based on typical values. Levelized costs based on maintenance costs of 1% of the initial capital investment per annum and a discount rate of 8% with a ten year payback period.

<sup>xxi</sup> Renewable Energy World, Adapted from Germany's PV financing schemes and the market by Ingrid Weiss and Peter Sprau, Jan-Feb 2002

<sup>xxii</sup> see note (ii)

The European Distributed Energy Service, The Real Costs of Emerging Distributed Energy Technologies, June 2002

California Energy Commission, Distributed Energy Resource Guide, available at <http://www.energy.ca.gov/distgen/index.html>

US Environmental Protection Agency, Introduction to CHP technologies, available at <http://www.epa.gov/CHP/pdf/Intro%20to%20Cat%20of%20Tech.pdf>

Navigant Consulting Inc. The Challenging Face of Renewable Energy, United Nations Environment Programme (UNEP), Energy Technology Factsheet, Small Scale Hydro



WADE – World Alliance for  
Decentralized Energy

15 Great Stuart Street  
Edinburgh  
EH3 7TP

Tel: +44 131 625 3333

Fax: +44 131 625 3334

[info@localpower.org](mailto:info@localpower.org)