

AMTECH News



December - 2003

INNOVATION

Being No.1 is NOT easy, We just make it look that way.

'The **FIRST** 5th GENERATION IGBT i.e. **CSTBT** based NEW **HATSU** series of **INVERTER.**'

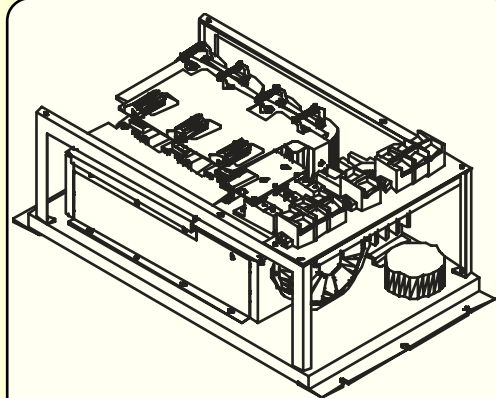

Delivering the 'PROMISE' of always offering customers with cutting-edge technology & innovative products.

Testimonials



Higher case temperatures with lower losses.

Mitsubishi is proud to offer **NF-SERIES IGBTs**. Utilizing a 5th generation CSTBT (Carrier Stored Trench Gate Bipolar Transistor) chip, the Powerex NF-Series IGBT is a cut above the competition. Compared to equivalent competitor devices, this design offers a technological breakthrough that allows operation at **higher case temperatures with lower losses**. As a result, the customer has a choice of two beneficial options. First, by using a higher rated Powerex NF IGBT, an **increase in reliability** will be achieved. Second, a lower rated Powerex NF-Series IGBT not only matches the reliability of competitors' higher rated devices, but also offers a **cost savings**

- Recommended for all new IGBT designs.
- 5th Generation CSTBT Chip Technology
- H-Series Package Compatible.
- Low Inductance U-Series Package Technology.
- Prototype quantities available.
- 600V - Duals from 150A to 600A
- 1200V Duals from 100A to 600A

Inside

New-Product Launched

Power Unit for Excimer Laser (Pulsed Power)

Page 2 & 3

@ AMTECH'S business partner

Meidensha Corporation, Japan

Page 4

Techno Talk

Variable speed drive & motors.

Page 5 & 6

Application Case Study

Energy saving in blower (AHU Plant)

Page 7

Our Marketing Network

Page 8

Editor :

Mr. Atul Suthar

Regarding e-Business, technical query please contact Ms. Dipti Shah at : info@amtechelectronics.com

Make a note of the 'TECHNOLOGY'!

**Dear Customers,
You will hear it again
often in future
years to follow; from
competitors.**

New- Product Launched



**Power Unit for Excimer Laser
(Pulsed Power)**



The growth of the advanced information society has stimulated the needs for semiconductor integrated circuits. The integration degree of an integrated circuit (high density circuit pattern) is dependent on the level of the minute processing technologies. The circuit pattern is an essence of exposure technology for laser beam radiation. The key is the performance of a short wave laser beam with a momentary high energy. Resulting from the recent improvement of power electronics, a high power semiconductor switch, replacing of a thyatron, has been developed for use as a pulse source for laser beams. Making full use of high power semiconductors, a momentary high energy is generated by the power unit for the excimer laser.

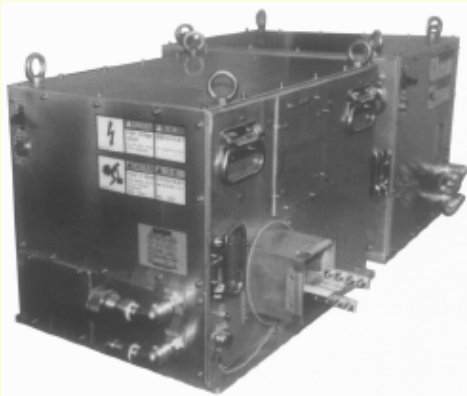

Features

1. **Compactness for the power unit (1/10 of the thyatron type)**
2. **High accuracy for the output pulse voltage (dispersion within 2%)**
3. **Long life for the power unit (only minimum maintenance in 4 years)**
4. **Improvement for the rising steepness (26.3kV/140ns)**

Basic Specifications

| Model | Type 600pps | Type 1000pps |
|------------------------------|------------------|------------------|
| Specifications | | |
| Max. repetitions (pps) | 600 | 1000 |
| Max. output voltage (kV) | 24kV | 26kV |
| Output pulse width (ns) | 200 or less | 150 or less |
| Jitter(ns) | 1000 or less | 100 or less |
| Output Voltage stability (%) | Within ± 1.5 | Within ± 1.5 |

Pulse Generator, Compressor Circuit

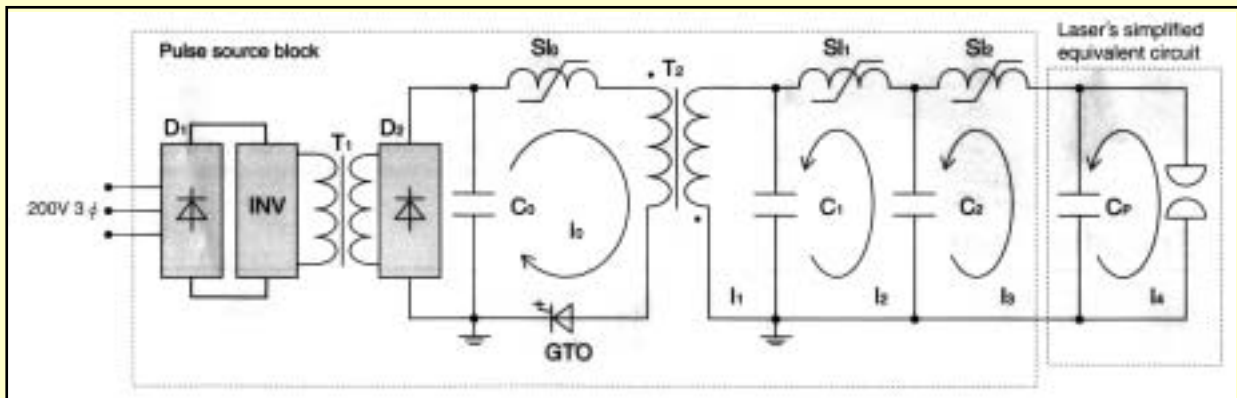

Continue to Next Page

Continue from previous page.....

Internal Laser Configuration and Pulse Source

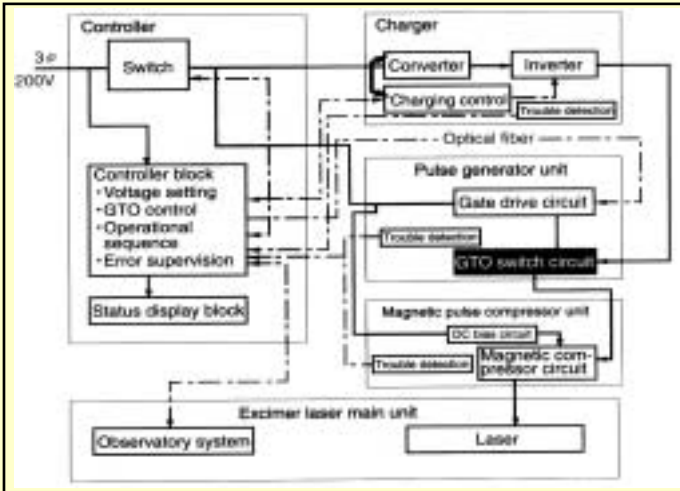

Pulses are fed to the discharge tube that generates a laser beam. The essential part of this power source is a combination of the pulse generator unit and the magnetic pulse compressor unit. The power semiconductor (GTO) generates sharp and high energy pulses.

Performance

■ Stable laser output characteristics

The variation in the monochromatic performance of the laser beam is minimal. The changes in the spectrum's half value width and purity width are only 5000 million pulses (for a one year amount of semiconductor production) as compared with the initial operating conditions. This performance implies high stability.

■ High pulse rising steepness

A rising steepness of 26.3kV / 140ns is secured.

■ High voltage accuracy

The dispersion in the pulse crest values is kept within 2%. A high stability is secured with a time axis fluctuation of 82ns.

● No. of operating pulses and performance change in excimer laser main unit

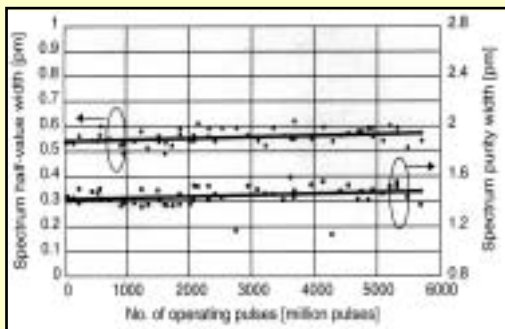

● Pulse source output characteristics

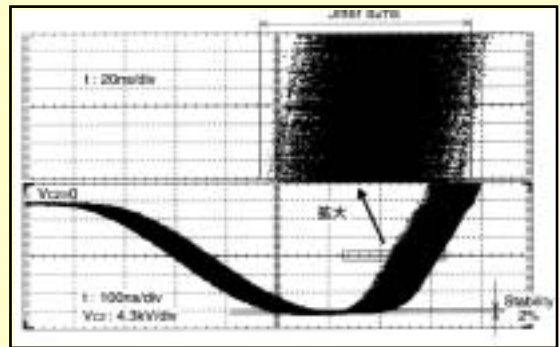

● Pulse source output waveform

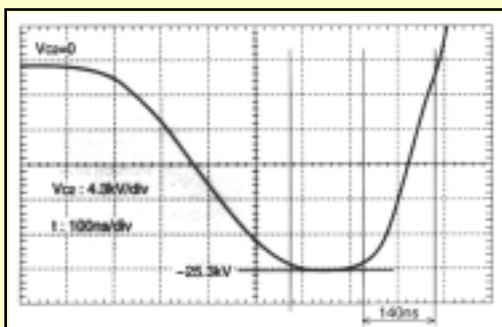



@ AMTECH'S business partner
MEIDENSHA CORPORATION, JAPAN

Meiden Variable Speed Drives

< Products >

General Purpose

VT230S Series
0.4 - 650kW

Elevator

Mid-Low Speed
0.75 - 1.75m/m
High Speed
2 - 15m/S

PM Servo

PMD400 Series
3.7 - 200kW

Textile Machines

VT630 Series
6 - 250kVA
VT636 Series
0.25 - 25Kva x 6 Drive

Dynamometer System

VT310DY Series
75 - 550kW

Medium Voltage

CG700 Series
500 - 10,000kW

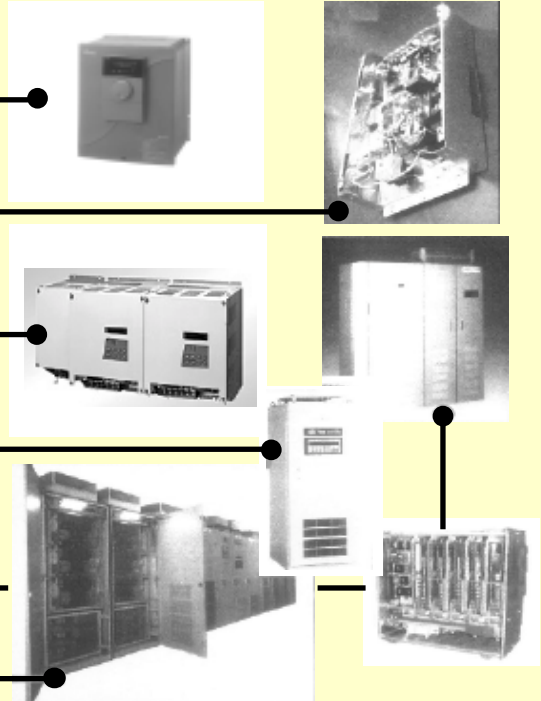

Meiden Motors & Drives

Other Motors & Drives

AC MOTORS FOR FORK LIFT TRUCKS

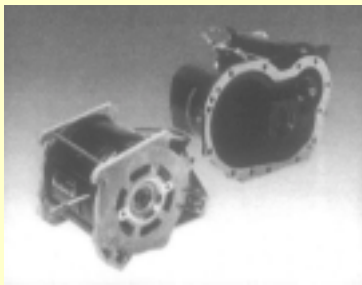

ENERGY SAVING PM MOTORS



VT310DY AC DRIVES FOR DYNAMOMETERS



FREC DYNAMOMETER



CG700 MEDIUM-VOLTAGE AC DRIVES





VARIABLE SPEED DRIVES AND MOTORS

TITLE : 6. ALTERNATIVE PREVENTATIVE METHODS

6.5 Motor Termination Unit

Some manufacturers produce series resistive/capacitive filters which may be locally connected at the motor terminals (usually as an extra box mounted near to the motor). The fast rising incident pulse sees the capacitor as a short circuit and the resistive element is temporarily connected across the end of the cable. If this resistor approximates to the characteristic impedance of the cable, overvoltages will not occur. As the capacitor charges, the current through the circuit reduces - therefore the losses in the resistor are limited to the rising edge duration. Typically, these filters add around 0.5 - 1.0% losses. For example illustrated in **Figure 18(d)** the peak voltage is now only 800V with a rise time of 2 μ s which should be suitable for most motors. To date, these devices have not been popular. One concern is that the parallel connection would be compromised thereby subjecting the motor to the high transients without any warning. Some users [4] have reported potential difficulties in matching the inverter current rating to the motor rating to obtain the inherent I^2t protection facilities available on many drives (presumably due to the terminator capacitive charging current). Termination units must not be used with motors designed for use in explosive atmospheres (Explosive Atmosphere Approval : The application of inverters to 'Ex' motors may invalidate the hazardous area certification - refer to the motor manufacturer).

6.6 Relative Characteristics of Preventative Measures The relative motor terminal voltage characteristics [5] of the preventative measures discussed above are shown in **Figure 18** and should be compared with the earlier **Figure 6(c)**. The mitigation methods below are specific to the motor/inverter installation and the actual selection should therefore be advised by the drive supplier.

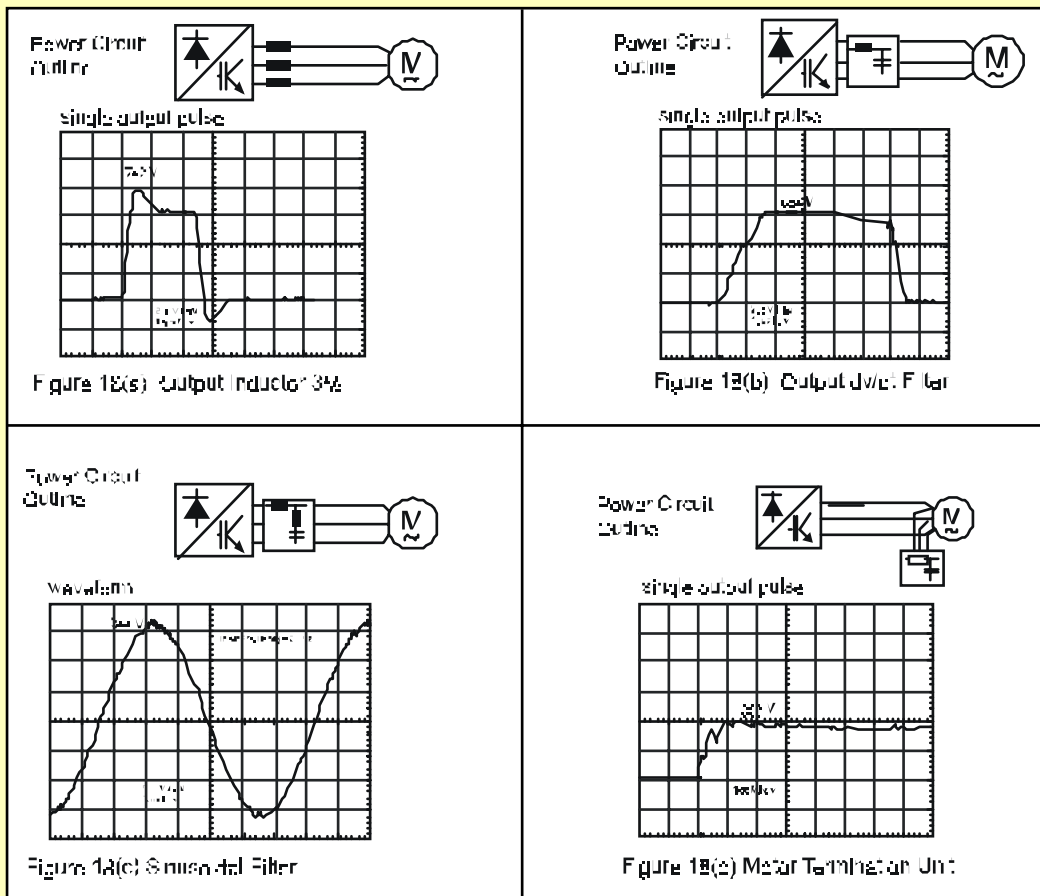

Note scale changes

Figure 18: Relative characteristics of alternative preventative measures.

Continue to Next Page



VARIABLE SPEED DRIVES AND MOTORS

TITLE : 6. ALTERNATIVE PREVENTATIVE METHODS

6.7 Cost Comparisons for Preventative Measures

In considering the relative merits of the competing solutions, the issue of costs should also be considered. The table below gives some indications.



| TYPICAL RELATIVE COSTS - DRIVES AND PREVENTATIVE MEASURES (MOTOR = 100%) | | | | | |
|-----------------------------------------------------------------------------|-------|-------------------------------------------------------------------------------------|-------------------------------------------------------------------------------------|--------------------------------------------------------------------------------------|---------------------------------------------------------------------------------------|
| RATING | DRIVE | PREVENTATIVE MEASURE | | | |
| | | OUTPUT INDUCTOR | OUTPUT dv/dt FILTER | SINUSOIDAL FILTER | MOTOR TERMINATION UNIT |
| 2.2kW, 415V | 350% | 75% | 440% | 330% | 170% |
| 75kW, 415V | 220% | 15% | 100% | 150% | 10% |
| 250kW, 415V | 120% | 5% | 65% | 110% | 3% |
| 160kW, 690V | 150% | 15% | 40% | N/A | 4% |
| 250kW, 690V | 140% | 15% | 40% | N/A | 2% |
| 500kW, 690V | 140% | 15% | 35% | N/A | 1% |
| POWER CIRCUIT OUTLINE | |  |  |  |  |

Table 2 : Additional preventative methods and costs

TITLE : 7. APPLICATION SPECIFIC NOTES

7.1 Cable Capacitance Effects

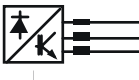
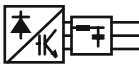
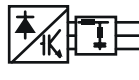
In addition to the peak voltage effects, total motor cable length should be considered in the context of instantaneous current peaks. At each inverter output pulse, the distributed cable capacitance ($C_1 - C_n$ in Figure 3) must be charged and discharged. For small motors with 'long' cables, the cable charging currents may be of the same order as the motor rated current! Cable charging currents may cause nuisance inverter overcurrent tripping. This leads to recommendations for each inverter frame size regarding the maximum cable lengths for both shielded (braided or armoured) or unshielded cables and may vary from 10m on very small drives to above 250m on high power drives. Mitigation measures such as additional reactors, transformers or filters may be used to extend the maximum cable length - refer to the technical catalogues of the particular inverter type.

7.2 Combined Inverter/Motor Solutions

In the mid 1990's manufacturers introduced the combined motor inverter topologies in which the inverter is integrally mounted within the motor enclosure, typically in the terminal box or sometimes as an extension to the motor casing. The very short cable length between the inverter output connections and the motor windings limits the reflections and therefore the peak voltage problems do not exist. Taken in the context of the additional benefits of simplified installation, reduced EMC problems and lower overall costs, this solution is well suited to lower power applications and is now rapidly gaining market acceptance.

Continue to Next issue

Application Case Study

TITLE : ENERGY SAVING IN BLOWER (AHU PLANT)

HOST ORGANIZATION : M/S CADILA HEALTH CARE, AHMEDABAD
PERFORMED BY : AMTECH ELECTRONICS (INDIA) LTD. IN OCTOBER 2003
INDUSTRY : PHARMACEUTICAL
APPLICATION : BLOWER (AHU PLANT) MAKE : CITIZEN
MOTOR RATING : 3 PHASE AC INDUCTION MOTOR
HP - 7.5HP **VOLT** - 415V
Amp - 11A **RPM** - 2860

PREVIOUS SYSTEM : 1. D.O.L starter used for motor operation.
 2. Damper used for Airflow control.

PROBLEM OBSERVED : 1. Very high starting current kick.
 2. As no smooth start, the vibration in machine was high, resulting in reduction of life of mechanical system and motor.
 3. Energy loss due to full speed operation for all the time.

PRESENT SYSTEM : Required air flow control by varying the speed of motor through 7.5HP AXPERT VT230S AC Variable Frequency Drive.

| | FREQ. | KW (Consumption) | Damper Position |
|---------------------------------|--------------|-------------------------|------------------------|
| Previous System (Without Drive) | : 50 Hz. | 5.4 KW | 70 to 80 % Open |
| Present System (With Drive) | : 35 to 40Hz | 4.0 KW | 100 % Open |

SYSTEM BLOCK DIAGRAM :

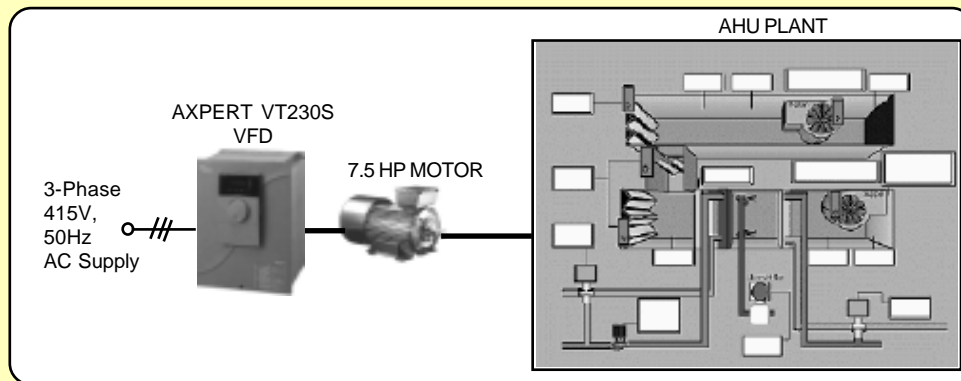

MERITS OF NEW SYSTEM: 1. Energy saving due to speed reduce of blower through AC VFD.
 2. Silent operation & no vibration resulting in longer life of the machine and motor.
 3. Speed of the blower is easily controlled through VFD as per requirement
 4. Precise control of plant parameters.

ECONOMICAL ANALYSIS :

| | |
|-------------------------------------|-----------------------------------|
| 1. Without drive energy consumption | : 5.4 KW / Hour |
| 2. With AC drive energy consumption | : 4.0 KW / Hour |
| 3. Energy saving | : 1.4 KW / Hour |
| 4. Energy saving per day | : 1.4 KW X 24 Hours = 33.6 KWH |
| 5. Working Days | : 320Days. |
| 6. Energy saving per year | : 320 Days X 33.6 KWH = 10752 KWH |
| 7. Tariff rate | : 5.0/-Rs. / Unit (Max.) |
| 8. Energy saving per year in rupees | : 53760 /- Rs. |
| 9. Payback period | : 7 Month (Approx) |